

**ABS
BRAKING**

FULLY SUSPENDED WITH 4 WHEEL ABS DISC BRAKING. JCB V-TRONIC TRANSMISSION.

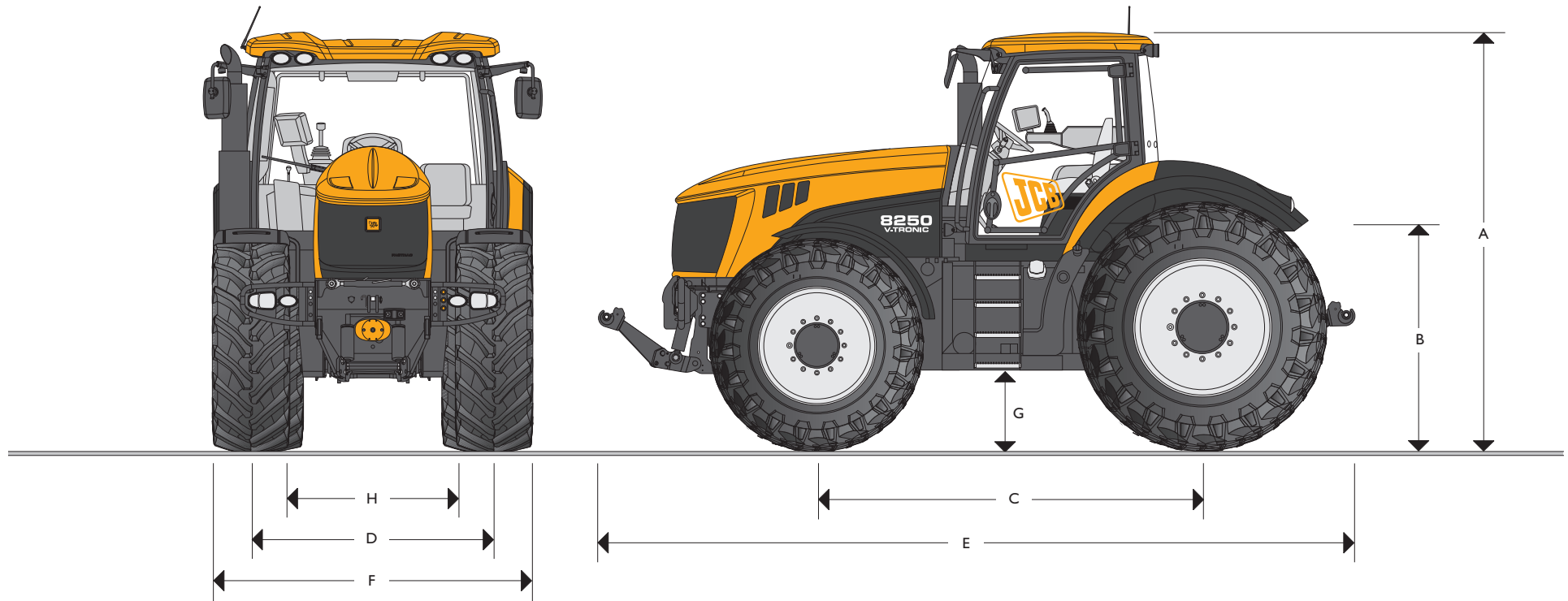

STATIC DIMENSIONS

Tyres	540/65 R38 Front and 710/70 R38 Rear	Tyres	540/65 R38 Front and 710/70 R38 Rear
	m (ft-in)		m (ft-in)
A	Height to exhaust	E	Overall length
B	Height to deck	F	Overall width
C	Wheelbase	G	Ground clearance
D	Track width (front/rear)	H	Width between tyres
	3.38 (11-1)		5.65 (18-6)
	1.51 (4-11)		2.55 (8-4)
	3.12 (10-3)		0.47 (1-6)
	2.03 (6-8) / 1.84 (6-0)		1.10 (3-7)



ENGINE

Make		Cummins
Model		QSC
Rated engine speed	rpm	2200
DIN hp at rated speed		248
Gross hp at rated speed		260
Gross kW at rated speed		194
Max torque @ 1400 rpm	Nm	1179
Torque back up		29%
Injection		CM 850 Common Rail
No of cylinders		6
Capacity	cc	8268
Bore	mm	114
Stroke	mm	135
Cooling		Water
Air cleaner		Powercore dry element
Aspiration		Turbocharged and intercooled

ELECTRICAL SYSTEM

System voltage	Volt	12
Alternator output	Amp	160
Battery capacity	Amp hour	2 x 110 (950 cold cranking amps)

Electrical wiring – to IP67 standard.

CAPACITIES

	litres (UK gal)
Fuel tank	600 (132)
Hydraulic tank	180 (40.0)

SUSPENSION

Front: Coil spring and damper; microcellular secondary spring.
Rear: Hydro-pneumatic self levelling.

HYDRAULICS

3 point linkage: Electronic draft/position intermix, rate of drop, adjustable lift height plus external lift and lower.
Rear hitch: 10,000kg (22,045lb) Category III; Quick attach hook ends, eye end top link.
Front hitch (optional): Lift capacity at link ends – 3500kgs, Category II; Quick attach hook ends, folding arms.

AUXILIARY HYDRAULICS

		Standard	Optional
Max oil flow	l/min	148	210
Flow at rated engine speed	l/min	132	187
Flow per slice	l/min	100	140

Operating pressure:	210 bar
Spool valves:	Electronic 4 position double acting with flow and time control, float position and zero leak.
Standard:	3 spool valves to the rear
Optional:	4 spool valves to the rear. Load sensing hydraulic connection. 1 or 2 front supplies. Front free flow return.
Couplers:	Deluxe Quick release/spill-off piped to reservoir (front and rear).
Pipework/hose:	BSP standard.

POWER TAKE OFF

Type:	Fully independent to front and rear (front optional).
Actuation:	Electro-hydraulic.
Rear PTO speeds Option 1:	540rpm @ 2050 engine rpm 1000rpm @ 2030 engine rpm
Rear PTO speeds Option 2:	540rpm @ 1570 engine rpm 1000rpm @ 2030 engine rpm
Rear PTO output spline:	6 or 21 spline 1 $\frac{3}{8}$ " diameter 6 or 20 spline 1 $\frac{3}{4}$ " diameter (options)
Front PTO speed:	1000rpm @ 2030 engine rpm
Front PTO output spline:	21 1 $\frac{3}{8}$ " diameter or 20 1 $\frac{3}{4}$ " diameter
PTO power:	225hp (168kW)
Speed change:	Electro-hydraulic in cab switch. Front PTO only available at 1000rpm.

AXLES

Type:	Beam with outboard epicyclic reduction hubs.
Wheel mountings:	10 stud front axle 16 stud rear axle
Four wheel drive selection:	On the move engage/disengage using rocker switch.
Differentials:	Front and rear locking with electro-hydraulic soft engagement.

STEERING

Type:	Re-circulating ball with power assistance and assisto ram.
Column:	Tilt and telescope adjustable.
Turning circle:	Kerb to kerb 14.8m

BRAKES

Type:	Outboard discs with twin calipers and ABS on all four wheels.
Operation:	Air over hydraulic to EEC truck specification.
Park brake:	Independent disc on transmission output.
Actuation:	Sprung on, air pressure off.
Trailer brakes:	Twin line air brakes. Single line hydraulic brakes for speeds up to 20mph. Air trailer brake automatically applied by tractor park brake. ABS 12v trailer supply socket as standard.



TRANSMISSION

Type: 2 range continuously variable transmission with 6 modes of operation

Speeds: Low Range 0 – 45kph
High Range 0 – 65kph

Powershift mode			
	Gear	Forward Speed km/hr	Reverse Speed km/hr
High Range	10	67.1	–
	9	65.2	–
	8	57.3	–
	7	45.1	45.1
	6	36.4	36.4
	5	27.0	27.0
	4	21.2	21.2
	3	15.7	15.7
	2	10.8	10.8
	1	7.5	7.5
Low Range	15	42.8	–
	14	34.2	–
	13	26.3	–
	12	21.1	21.1
	11	17.0	17.0
	10	13.6	13.6
	9	11.0	11.0
	8	8.9	8.9
	7	6.9	6.9
	6	5.3	5.3
	5	4.4	4.4
	4	3.5	3.5
	3	2.8	2.8
	2	2.0	2.0
	1	0.4	0.4

540/65 R38 and 710/70 R38 tyres at rated engine speed (2200rpm)
All other modes utilise stepless ratios.

VEHICLE WEIGHTS

Based on a 8250 shipping weight with no fuel on 540/65 R34 front and 650/65 R38 rear tyres with no driver and no ballast.

	Front axle	Rear axle	Total
	kg	kg	kg
Machine with front weight tray	5100	5035	10,135

WHEELS AND TYRES

4 welded wheels. Front directional and rear fixed and enclosed fenders. Fixed cab mounted fenders.
All tyres are speed rated for 65kph

Factory fit	Front tyres	Track width mm (in)	Rear tyres	Track width mm (in)
Firestone	540/65 R34	1990 (78)	650/65 R38	1900 (75)
Pirelli	540/65 R34	1990 (78)	650/65 R38	1900 (75)
Pirelli	540/65 R38	1990 (78)	710/70 R38	1834 (72)

Vehicle width is retained within 2550mm.

CAB

High specification, single door, full width, low noise.

Standard equipment includes:

Fully automatic climate control.
Air suspension seat with armrest mounted transmission and auxiliary controls.
Colour touch screen display, providing transmission information and setup capability.
Electronic spool valves.
Full dust filtration.
Tinted glass.
Front and rear wash wipe.
Electrically adjustable right hand rear view mirror.
Full road lighting equipment.
Auxiliary electrical and speed sensor sockets.
Full size passenger seat.
Lap belt for driver and passenger.
Side console illumination.
Slimline blue backlit dashboard.
Storage compartment.
Radio preparation with single DIN slot and four speakers.
Sun blind.
Cable access through rear window.
Rear fender mounted raise/lower and PTO cut out switches.
8 front and 6 rear worklights.
Headland management system.

OPTIONAL EQUIPMENT

Front linkage (Category II) with electronic control and external raise/lower.
Front 1000rpm PTO with 21 spline or 20 spline output shaft.
Four electronic spool valves.
Hi-flow hydraulics.
Load sensing hydraulic connection.
Front weight.
Rear deck weight.
1 or 2 front hydraulic services.
Front free flow return.
20 spline 1 $\frac{3}{4}$ " PTO shaft.
6 spline 1 $\frac{3}{4}$ " PTO shaft.
Radar and performance monitor.
Deluxe heated drivers seat.
Heated front and rear screens with heated and electric mirrors.
Left hand electrically adjustable mirror.
Xenon worklight package (2 front, 2 rear Xenon with 6 front, 4 rear standard).
In cab cooler/freezer.
Auxiliary audio input.
Deluxe double DIN radio preparation.
Interior rear view mirror.
Rear deck mounted toolbox.
Automatic rear linkage stabilisers.
750/1000 rpm PTO option.
Knuckle end top link.

A GLOBAL COMMITMENT TO QUALITY

JCB's total commitment to its products and customers has helped it grow from a one-man business into Britain's largest privately owned manufacturer of backhoe loaders, crawler excavators, wheeled excavators, telescopic handlers, wheeled loaders, dump trucks, rough terrain fork lifts, industrial fork lifts, mini/midi excavators, skid steer loaders, tractors and compaction equipment.

By making constant and massive investments in the latest production technology, the JCB factories have become some of the most advanced in the world.

By leading the field in innovative research and design, extensive testing and stringent quality control, JCB machines have become renowned all over the world for performance, value and reliability.

And with a global sales and service network of more than 650 dealers and agents, we aim to deliver the best customer support in the industry.

Through setting the standards by which others are judged, JCB has become one of the world's most impressive success stories.

