

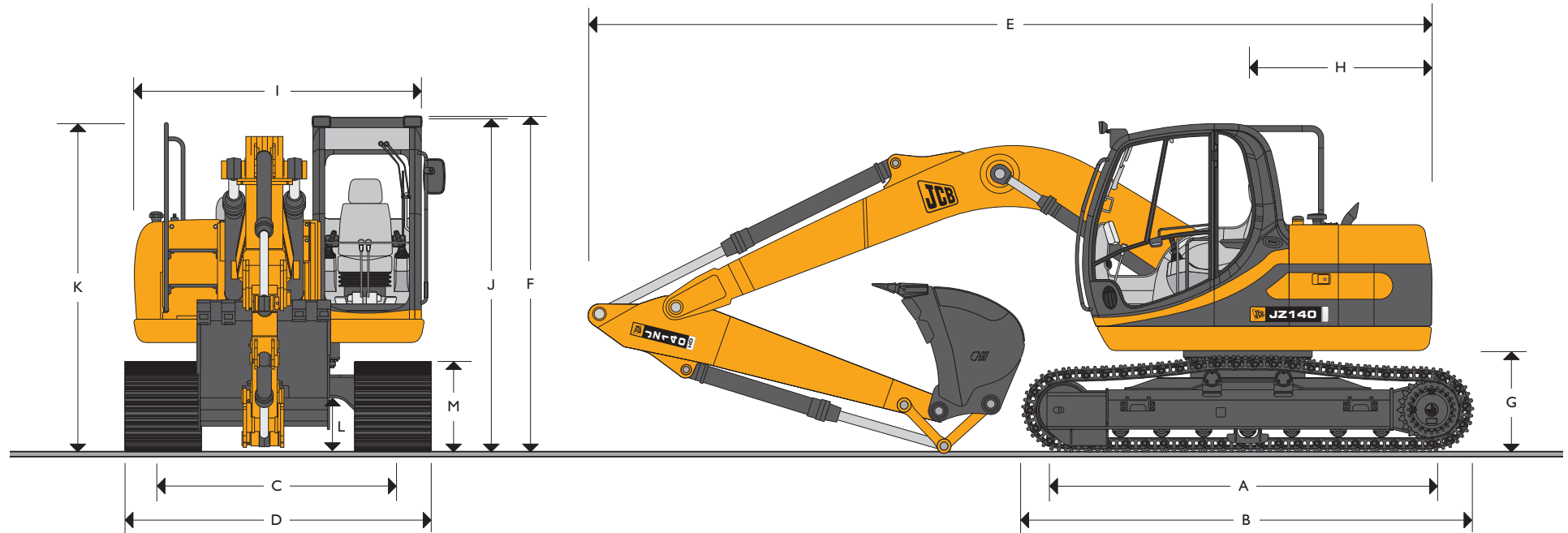

MAX. OPERATING WEIGHT: 15890 kg (35031 lb) – 16650 kg (36707 lb) WITH BLADE    MAX. ENGINE POWER: 73 kW (98 hp)



STATIC DIMENSIONS – JZ140 MONOBOOM

Dimensions in millimetres (ft-in)			
A	Track length on ground	2865 (9-5)	
B	Undercarriage overall length	3607 (11-10)	
C	Track gauge	1990 (6-6)	
D	Width over tracks (500mm trackshoes)	2490 (8-2)	
D	Width over tracks (600mm trackshoes)	2590 (8-6)	
D	Width over tracks (700mm trackshoes)	2690 (8-10)	
D	Width over tracks (850mm trackshoes)	2840 (9-4)	
Dipper lengths		<b>2.1m (6ft 11in)</b>	<b>2.5m (8ft 2in)</b>
E	Transport length with Monoboom	7370 (24-2)	7380 (24-3)
F	Transport height with Monoboom	2850 (9-4)	3240 (10-8)

Dimensions in millimetres (ft-in)	
G	Counterweight clearance
H	Tail swing radius
I	Width of superstructure
J	Height over cab
K	Height over grab rail
L	Ground clearance
M	Track height

\*Machine in transport position



MAX. OPERATING WEIGHT: 16600 kg (36597 lb) – 17360 kg (38272 lb) WITH BLADE MAX. ENGINE POWER: 73 kW (98 hp)

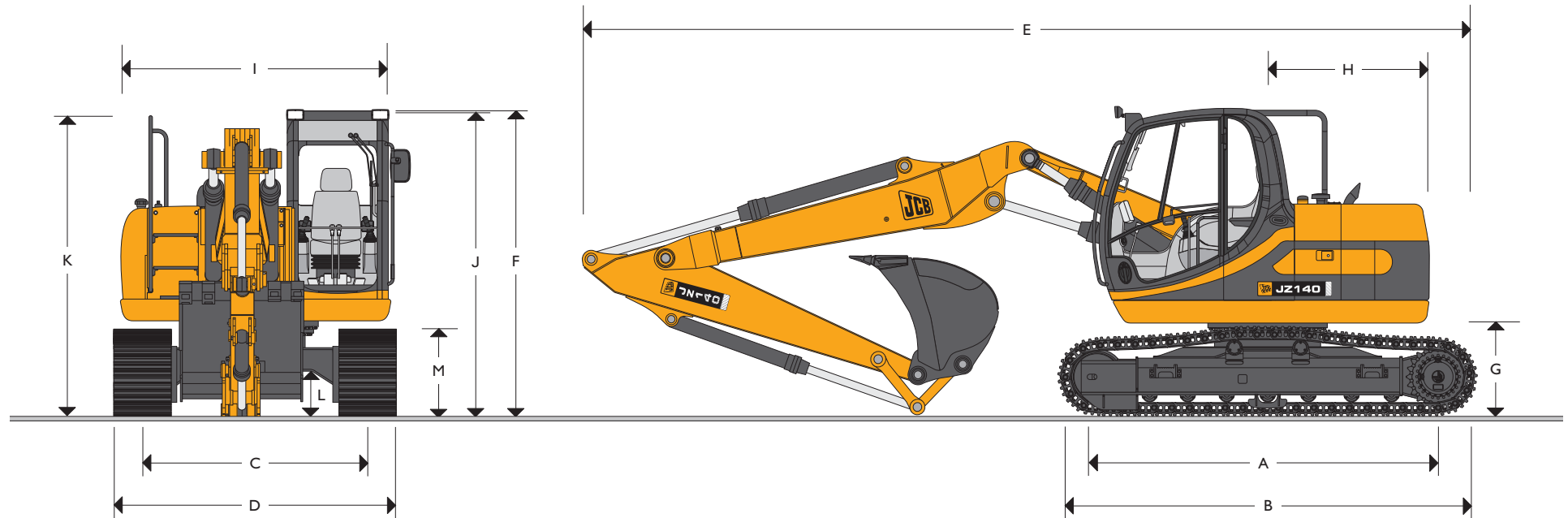

STATIC DIMENSIONS – JZ140 T.A.B.

Dimensions in millimetres (ft-in)			
A	Track length on ground		2865 (9-5)
B	Undercarriage overall length		3607 (11-10)
C	Track gauge		1990 (6-6)
D	Width over tracks (500mm trackshoes)		2490 (8-2)
D	Width over tracks (600mm trackshoes)		2590 (8-6)
D	Width over tracks (700mm trackshoes)		2690 (8-10)
D	Width over tracks (850mm trackshoes)		2840 (9-4)
Dipper lengths			
	2.1m (6ft 11in)	2.5m (8ft 2in)	3.0m* (9ft 10in)
E	Transport length with T.A.B.		7675 (25-2) 7640 (25-1) 8125 (26-8)
F	Transport height with T.A.B.		2850 (9-4) 2850 (9-4) 3331 (10-11)

Dimensions in millimetres (ft-in)	
G	Counterweight clearance 910 (3-0)
H	Tail swing radius 1420 (4-7)
I	Width of superstructure 2500 (8-2)
J	Height over cab 2840 (9-3)
K	Height over grab rail 2840 (9-3)
L	Ground clearance 460 (1-6)
M	Track height 811 (2-8)

\*Machine in transport position



### ENGINE

<b>Model</b>	Isuzu 4JJ1X EU Stage IIIA EPA Tier 3 compliant.
<b>Type</b>	Water cooled, 4-stroke, 4-cylinder in-line, common rail direct injection, turbocharged intercooled diesel.
<b>Rated power (ISO 14396 (SAE J1995))</b>	73kW (98hp) at 2000rpm.
<b>Piston Displacement</b>	2.999 litres (0.6 UK gal).
<b>Injection</b>	Electronic injection.
<b>Air Filtration</b>	Dry element with secondary safety element and in cab warning indicator.
<b>Cooling</b>	Large capacity radiator.
<b>Starting system</b>	24 volt – 4.5kW.
<b>Batteries</b>	2 x 12 volt Heavy Duty.
<b>Alternator</b>	24 volt 50 amp.
<b>Refuelling pump</b>	Electric type.

### SWING SYSTEM

<b>Swing motor</b>	Axial piston type.
<b>Swing brake</b>	Hydraulic braking plus automatic spring applied disc type parking brake.
<b>Final drive</b>	Planetary reduction.
<b>Swing speed</b>	12.8 rpm.
<b>Swing gear</b>	Large diameter, internally toothed fully sealed grease bath lubricated.
<b>Swing lock</b>	Multi position switchable brake.

### UNDERCARRIAGE

<b>Construction</b>	Fully welded, "X" frame type with central bellyguarding and sloping sidemembers with dirt relief holes under top rollers.	
<b>Recovery point</b>	Front and rear.	
<b>Upper &amp; lower rollers</b>	Heat treated, sealed and lubricated.	
<b>Track adjustment</b>	Grease cylinder type.	
<b>Track type</b>	Sealed and lubricated.	
<b>Track idler</b>	Sealed and lubricated, with spring cushioned recoil.	
<b>Track shoes</b>	500mm (20in.) triple grouser 600mm (24in.) triple grouser 700mm (28in.) triple grouser 850mm (33in.) triple grouser	
<b>Rollers and Shoes (each side)</b>	Upper rollers	2
	Lower rollers	7
	Track shoes	44

### HYDRAULIC SYSTEM

A variable flow load sensing system with flow on demand, variable power output and servo operated, multi-function open centre control. Machine auto warm up standard – maximises performance in cold conditions.

#### Pumps

Main pumps	2 variable displacement axial piston type.
Maximum flow	2 x 124 L/min (2 x 27.3 UK GPM).
Servo pump	Gear type.
Maximum flow	21 L/min (4.6 UK GPM).
Fan drive	Gear type. 40 L/min (8.8 UK GPM).

#### Control valve

A combined four and five spool control valve with auxiliary service spool as standard. When required twin pump flow is combined to boom and dipper services for greater speed and efficiency.

#### Relief valve settings

Boom/Arm/Bucket	314 bar (4554lb/sq.in)
With power boost	343 bar (4975lb/sq.in)
Swing circuit	279 bar (4045lb/sq.in)
Travel circuit	343 bar (4975lb/sq.in)
Pilot control	40 bar (569lb/sq.in)

A separate Cushion Control valve in the servo system provides cushioning of the boom and dipper spools selection and quick warm-up of the servo system.

#### Hydraulic cylinders

Double acting type, with bolt-up end caps and hardened steel bearing bushes. End cushioning is fitted as standard on boom, dipper and bucket rams.

Optional hose burst check valves available for boom and dipper rams.

#### Filtration

The hydraulic components are protected by the highest standard of filtration to ensure long hydraulic fluid and component life.

<b>In tank</b>	150 micron, suction strainer.
<b>Main return line</b>	10 micron, fibreform element.
<b>Plexus Bypass line</b>	1.5 micron, paper element.
<b>Pilot line</b>	10 micron, paper element.
<b>Hydraulic hammer return</b>	10 micron, reinforced microform element.

#### Cooling

Worldwide cooling is provided as part of a single face cooling pack, in conjunction with the engine water cooler.

### TRACK DRIVE

<b>Type</b>	Fully hydrostatic, three speed with autoshift between high and medium speed.
<b>Travel motors</b>	Variable swash axial piston type, fully guarded within undercarriage frame.
<b>Final drive</b>	Planetary reduction, bolt-on sprockets.
<b>Service brake</b>	Hydraulic counter balance valve to prevent overspeeding on gradients.
<b>Park brake</b>	Disc type, spring applied, automatic hydraulic release.
<b>Gradeability</b>	70% (35 deg) continuous.
<b>Travel speed</b>	High – 5.1 km/h (3.2 mph). Mid – 3.0 km/h (1.9 mph). Low – 2.0 km/h (1.2 mph).
<b>Tractive effort</b>	126kN (28326lb).



### EXCAVATOR END – MONOBOOM

Monoboom available along with a choice of dipper lengths to suit the requirements of reach, dig-depth, loadover height, tearouts and site versatility. Reserve strength is built into the fully welded structures for hydraulic hammer and other arduous operations. Fabricated bucket tipping links are provided with a choice of lift points. Strong, durable construction, large cross sections and multi plate fabrications to withstand high stress applications. The 4.7m (15ft 5in) boom is designed to ensure the optimum digging envelope when matched with the three dipper lengths. Low maintenance bronze alloy bushes with graphite plugs are fitted to boom base and boom to dipper pivots resulting in 1000 hour greasing intervals at these points.

### EXCAVATOR END – T.A.B.

Triple Articulated Boom (T.A.B.) with a choice of dipper lengths to suit the requirements of reach, dig-depth, loadover height, tearouts and site versatility. Reserve strength is built into the fully welded structures for hydraulic hammer and other arduous operations. Fabricated bucket tipping links are provided with a choice of lift points.

### CAB

Excellent digging, loading and positioning visibility results from the careful design of front, side and roof lights. All screens are tinted to improve in cab conditions. Fully opening front screen is very smooth to operate and as the lower screen is stored within the top screen frame it makes complete front screen opening easy, fast and convenient. Fresh air ventilation available from opening door window, opening slot in front screen and fully opening front screen. Parallelogram wash wiper for upper screen ensuring good wiped area for maximum visibility. Wiper motor is fitted in the left hand side of the roof screen so as not to affect bucket visibility when loading. Optional lower screen wiper available. Fresh air ventilation and heater with windscreen demister. Infinitely variable blower speed, temperature and recirculation control. Climate control. Fully adjustable deluxe suspension seat with arm rest adjustment and backrest recline. Radio with digital tuner fitted into the roof lining for maximum protection. Conveniently placed radio mute button incorporated into lower console. 12v power point and mobile phone holder built into the right hand console. Courtesy light can be operated from ground level and is illuminated for five minutes or until switched off improving operator access at night. Cab mounted roller blind protects operator from suns' glare through front or top screens.

### AMS – ADVANCED MANAGEMENT SYSTEM

Four selectable working modes link the operators control movements with the engine and hydraulic systems to maximise productivity and efficiency.

- A (Auto)** Up to 100% engine power and 100% flow. Gives variable power and speed depending on the operator's input, matching the demand for output and efficiency to the job. Power boost is automatically activated in this mode should hard conditions be encountered. Auto idle cuts in after a period of inactivity (between 5 and 30 seconds as set by the operator)
- E (Economy)** 80% engine power. 95% of hydraulic flow maximises economy while maintaining excellent output.
- P (Precision)** 55% engine power. 90% of hydraulic flow for fine control of grading operations.
- L (Lifting)** 55% engine power. 63% of hydraulic flow with permanent power boost for maximum lifting power and control.

The Auto mode allows the AMS processor to select the optimum operational performance to match the demands of the job while the three alternative modes give precise matching of application when specific tasks are undertaken.

The adjustable position monitor mounted on the front right hand pillar of the cab gives the operator a constant read out of mode, tracking range, operating temperature and a host of other information, while retaining excellent visibility of the monitor and the job being carried out.

The required flow for hammer applications can be set and stored in the AMS memory and is automatically activated whenever the hammer pedal is depressed.

A maintenance indicator warns of imminent service needs, and all servicing and basic checks can be carried out using only the in cab display.

### CONTROLS

- Excavator** All servo lever operated to ISO control pattern, independently adjustable to the seat.
- Tracks** Individually servo operated by foot pedal or hand lever. Speed selection via joystick button.
- Auxiliary** Via servo operated foot pedal.
- Control isolation** Via gate lock lever at cab entrance or panel switch.
- Engine speed** Dial type throttle control plus servo lever mounted one-touch idle control or separate selectable auto-idle with adjustable time delay using AMS.
- Engine stop** Ignition key operated and separate shut-down button.
- Horn** Operated via servo lever mounted button.
- Blade (optional)** Separate lever in cab.

**SERVICE CAPACITIES**

	Litres	UK Gal
Fuel tank	162	35.5
Engine coolant	14.0	3.1
Engine oil	11.6	2.6
Swing reduction gear	2.2	0.5
Track reduction gear (each side)	3.0	0.7
Hydraulic system	124.0	27.3
Hydraulic tank	73.0	16.1

**STANDARD / OPTIONAL EQUIPMENT**

**Standard Equipment:** Radiator fan guard; Cold start pre-heat; Auto engine warm up; Double element air cleaner; Heavy duty alternator; Electrics isolator; Heavy duty batteries; Cab & engine soundproofing; Cab heater & screen demister; Tinted glass; Interior light; Coat hook; Cigarette lighter; Ashtray; Operator's storage box with cargo net; Removable floor mat; Windscreen wash/wipe; Plug-in power socket; Automatic power boost; Auto-idle; One-touch engine speed control; Hydraulic cushion control; Plexus hydraulic oil filtration; HSP pressure test points; Auxiliary pipework mounting brackets; Work lights – boom & mainframe mounted; Undercarriage belly guarding; Upper structure under covers; Swing system cover; External mirrors; Handrail & non slip walk ways; Quick connect engine oil drain pipe; Front screen blind; Quick connect fuel tank drain pipe.

**Optional Equipment:** Hose burst check valves & overload warning system; Tipping link mounted lift points; General purpose buckets; Ditching/grading buckets; Quickhitches; Hydraulic hammers; Auxiliary pipework (full and low flow); Air conditioning or climate control; Additional cab mounted work lights; Rotating beacon; Rain guard; Biodegradable oil; Air suspension seat with heated pad and lumbar support adjustment; Electric refuelling pump; Track guides; Lower screen wiper; Radio; Backfilling/stabilising blade; Various track plate widths; Cab guard protection screens; Mesh screen guard; Seat belt; Fire extinguisher; Vandal cover kit; Travel alarm.

**WEIGHTS AND GROUND BEARING PRESSURES**

Machine equipped with 4.7m Monoboomb, 2.5m Dipper, Standard Excavating Bucket 1200mm wide, operator and full fuel tank.

Shoe Width	Operating Weight	Bearing Pressure
500mm (20in.)	14791kg (32609lb)	0.47kg/sq. cm. (6.68lb/sq. in.)
600mm (24in.)	15098kg (33285lb)	0.40kg/sq. cm. (5.69lb/sq. in.)
700mm (28in.)	15298kg (33276lb)	0.35kg/sq. cm. (4.98lb/sq. in.)
850mm (33in.)	15551kg (34284lb)	0.29kg/sq. cm. (4.12lb/sq. in.)

Machine equipped with 5.0m T.A.B., 2.5m Dipper, Standard Excavating Bucket, operator and full fuel tank.

Shoe Width	Operating Weight	Bearing Pressure
500mm (20in.)	15395kg (33940lb)	0.49kg/sq. cm. (6.97lb/sq. in.)
600mm (24in.)	15702kg (34617lb)	0.42kg/sq. cm. (5.97lb/sq. in.)
700mm (28in.)	15902kg (35058lb)	0.36kg/sq. cm. (5.12lb/sq. in.)
850mm (33in.)	16155kg (35616lb)	0.30kg/sq. cm. (4.27lb/sq. in.)

**OPTIONAL BLADE**

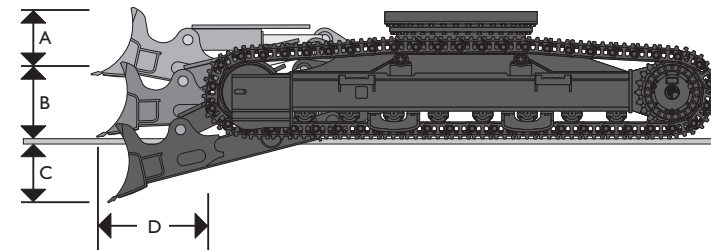

<b>A</b> Blade height	mm (ft-in)	515 (1-8)
<b>B</b> Blade lift above ground	mm (ft-in)	440 (1-5)
<b>C</b> Blade cut below ground	mm (ft-in)	520 (1-8)
<b>D</b> Blade forward of track	mm (ft-in)	410 (1-4)
Dozer width – 500mm tracks	mm (ft-in)	2510 (8-3)
Dozer width – 600mm tracks	mm (ft-in)	2610 (8-7)
Dozer width – 700mm tracks	mm (ft-in)	2710 (8-11)
<b>Additional weight with blade</b>		
500mm tracks	kg (lb)	747 (1647)
600mm tracks	kg (lb)	753 (1660)
700mm tracks	kg (lb)	759 (1673)

WORKING RANGE – JZ140 MONOBOOM

Boom length: 4.70m (15ft 5in)		
<b>Dipper length:</b>		<b>2.10m (6ft 11in)</b>
A	Maximum digging reach	mm (ft-in) 7970 (26-2)
B	Maximum digging reach (on ground)	mm (ft-in) 7820 (25-8)
C	Maximum digging depth	mm (ft-in) 5150 (16-11)
D	Maximum digging height	mm (ft-in) 8820 (28-11)
E	Maximum dumping height	mm (ft-in) 6430 (21-1)
F	Maximum vertical wall cut depth	mm (ft-in) 4580 (15-0)
G	Minimum swing radius	mm (ft-in) 2050 (6-9)
	Bucket rotation	182°
	Maximum dipper tearout (ISO 6015)	kgf (lbf) 7515 (16569)
	Maximum bucket tearout (ISO 6015)	kgf (lbf) 9375 (20667)
<b>Dipper length:</b>		<b>2.50m (8ft 2in)</b>
A	Maximum digging reach	mm (ft-in) 8340 (27-4)
B	Maximum digging reach (on ground)	mm (ft-in) 8200 (26-11)
C	Maximum digging depth	mm (ft-in) 5550 (18-3)
D	Maximum digging height	mm (ft-in) 9090 (29-10)
E	Maximum dumping height	mm (ft-in) 6700 (22-0)
F	Maximum vertical wall cut depth	mm (ft-in) 4980 (16-4)
G	Minimum swing radius	mm (ft-in) 2050 (6-9)
	Bucket rotation	182°
	Maximum dipper tearout (ISO 6015)	kgf (lbf) 6680 (14720)
	Maximum bucket tearout (ISO 6015)	kgf (lbf) 9375 (20667)
<b>Dipper length:</b>		<b>3.00m (9ft 10in)</b>
A	Maximum digging reach	mm (ft-in) 8790 (28-10)
B	Maximum digging reach (on ground)	mm (ft-in) 8660 (28-5)
C	Maximum digging depth	mm (ft-in) 6050 (19-10)
D	Maximum digging height	mm (ft-in) 9410 (30-10)
E	Maximum dumping height	mm (ft-in) 7020 (23-0)
F	Maximum vertical wall cut depth	mm (ft-in) 5440 (17-10)
G	Minimum swing radius	mm (ft-in) 2410 (7-11)
	Bucket rotation	182°
	Maximum dipper tearout (ISO 5016)	kgf (lbf) 5970 (13161)
	Maximum bucket tearout (ISO 5016)	kgf (lbf) 9375 (20667)

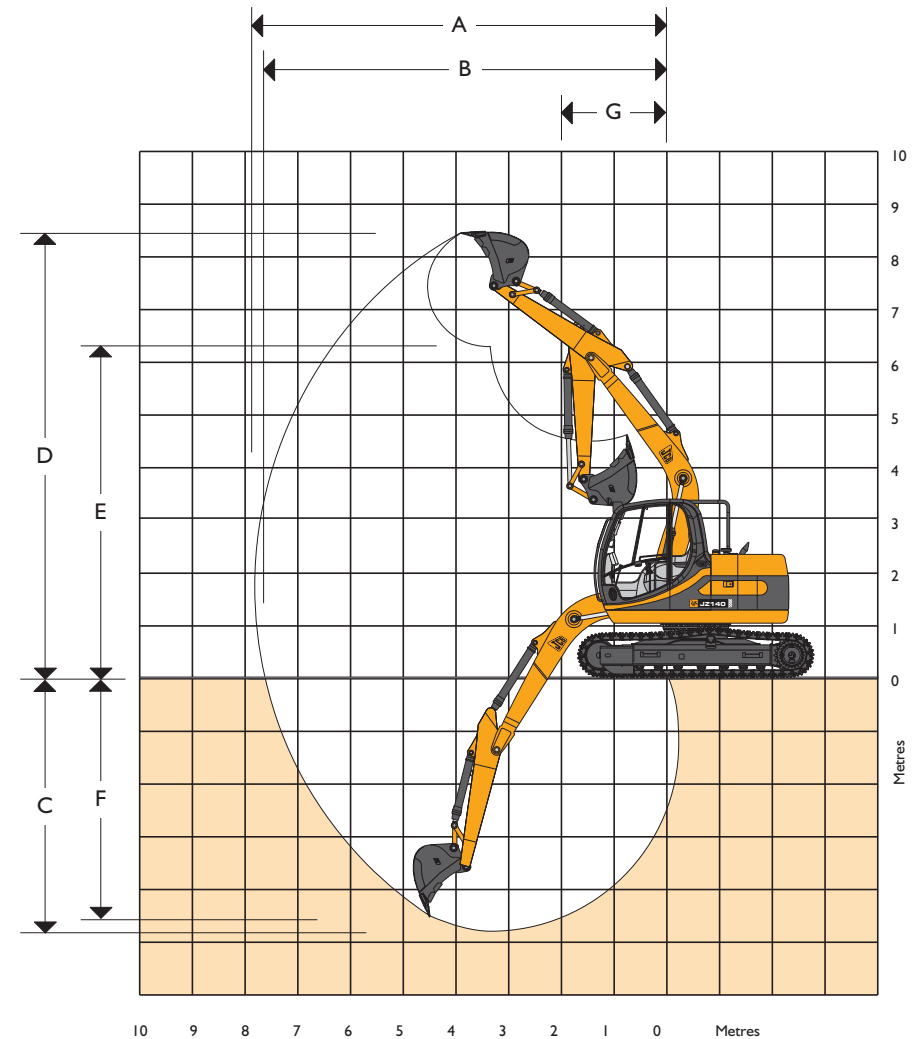

WORKING RANGE – JZ140 T.A.B.

Boom length: 5.00m (16ft 5in)		
<b>Dipper length:</b>		<b>2.10m (6ft 11in)</b>
A	Maximum digging reach	mm (ft-in) 8360 (27-5)
B	Maximum digging reach (on ground)	mm (ft-in) 8140 (26-8)
C	Maximum digging depth	mm (ft-in) 5350 (17-6)
D	Maximum digging height	mm (ft-in) 9345 (30-8)
E	Maximum dumping height	mm (ft-in) 6945 (31-7)
F	Maximum vertical wall cut depth	mm (ft-in) 4910 (16-1)
G	Minimum swing radius	mm (ft-in) 2050 (6-9)
	Bucket rotation	182°
	Maximum Dipper tearout (ISO 6015)	kgf (lbf) 7515 (16569)
	Maximum Bucket tearout (ISO 6015)	kgf (lbf) 9375 (20667)
<hr/>		
<b>Dipper length:</b>		<b>2.50m (8ft 2in)</b>
A	Maximum digging reach	mm (ft-in) 8750 (28-8)
B	Maximum digging reach (on ground)	mm (ft-in) 8525 (28-0)
C	Maximum digging depth	mm (ft-in) 5755 (18-10)
D	Maximum digging height	mm (ft-in) 9670 (31-8)
E	Maximum dumping height	mm (ft-in) 7245 (23-9)
F	Maximum vertical wall cut depth	mm (ft-in) 5310 (17-6)
G	Minimum swing radius	mm (ft-in) 2050 (6-9)
	Bucket rotation	182°
	Maximum Dipper tearout (ISO 6015)	kgf (lbf) 6680 (14720)
	Maximum Bucket tearout (ISO 6015)	kgf (lbf) 9375 (20667)
<hr/>		
<b>Dipper length:</b>		<b>3.00m (9ft 10in)</b>
A	Maximum digging reach	mm (ft-in) 9235 (30-3)
B	Maximum digging reach (on ground)	mm (ft-in) 9000 (29-6)
C	Maximum digging depth	mm (ft-in) 6260 (20-6)
D	Maximum digging height	mm (ft-in) 10070 (33-0)
E	Maximum dumping height	mm (ft-in) 7620 (25-0)
F	Maximum vertical wall cut depth	mm (ft-in) 5770 (18-11)
G	Minimum swing radius	mm (ft-in) 2410 (7-11)
	Bucket rotation	182°
	Maximum Dipper tearout (ISO 6015)	kgf (lbf) 5970 (13161)
	Maximum Bucket tearout (ISO 6015)	kgf (lbf) 9375 (20667)

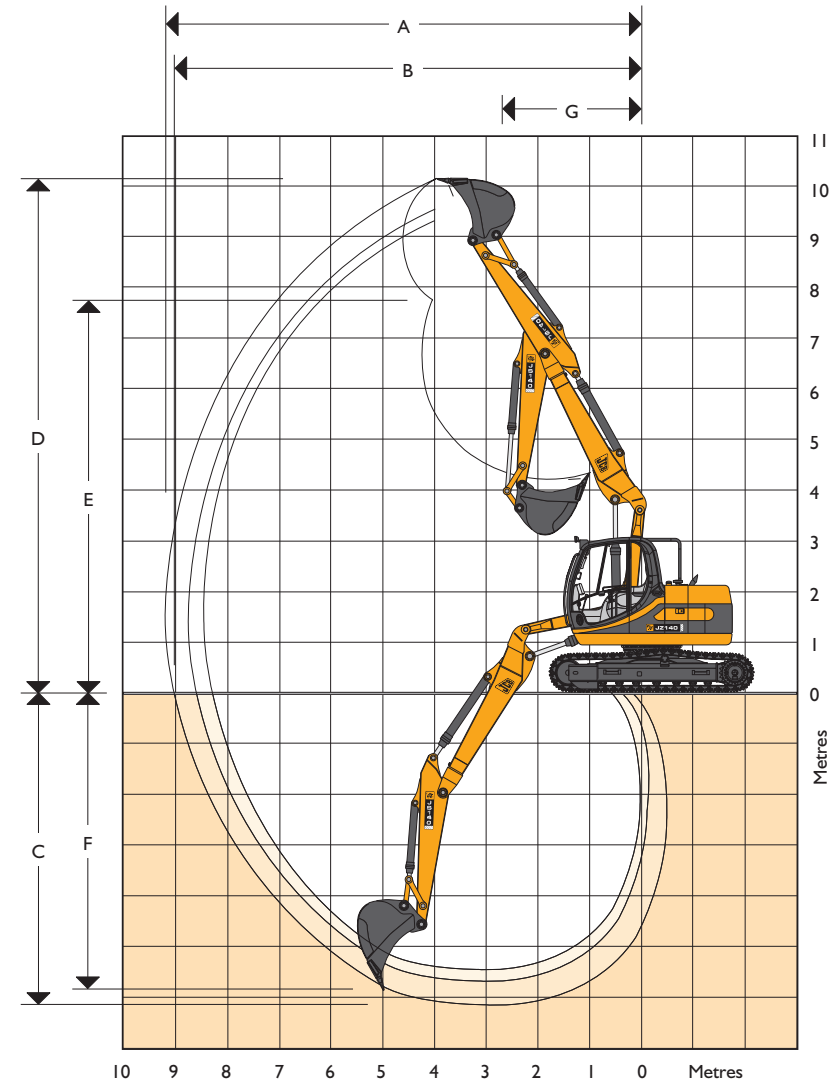

LIFT CAPACITIES – Dipper Length: 2.10m, 4.70m Monoboom, Trackshoes: 700mm, No bucket.

**JZI40 MONO**

Reach	1.5m (4ft 11in)		3m (9ft 10in)		4.5m (14ft 9in)		6m (19ft 8in)		7.5m (24ft 7in)		Capacity at Max Reach			
													mm	
Load Point Ht.	kg	kg	kg	kg	kg	kg	kg	kg	kg	kg	kg	kg		
7.5m (24.7ft)			3920*	3920*								3940*	3940*	3046
6.0m (19.8ft)					3290*	3290*						2950*	2950*	5042
4.5m (14.9ft)			3900*	3900*	3460*	3460*	3170*	2250				2700*	2200	6068
3.0m (9.10ft)			6070*	6070*	4180*	3400	3280	2200				2660*	1880	6604
1.5m (4.11ft)					4880	3160	3180	2100				2650	1760	6768
0m			6100*	5440	4710	3010	3100	2030				2720	1790	6590
- 1.5m (- 4.11ft)	5450*	5450*	8120*	5460	4670	2970	3090	2030				3070	2010	6038
- 3.0m (- 9.10ft)			6850*	5590	4650*	3050						3960*	2670	4986
- 4.5m (- 14.9ft)														

LIFT CAPACITIES – Dipper Length: 2.50m, 4.70m Monoboom, Trackshoes: 700mm, No bucket.

**JZI40 MONO**

Reach	1.5m (4ft 11in)		3m (9ft 10in)		4.5m (14ft 9in)		6m (19ft 8in)		7.5m (24ft 7in)		Capacity at Max Reach			
													mm	
Load Point Ht.	kg	kg	kg	kg	kg	kg	kg	kg	kg	kg	kg	kg		
7.5m (24.7ft)												2970*	2970*	3809
6.0m (19.8ft)					2880*	2880*						2380*	2380*	5530
4.5m (14.9ft)					3130*	3130*	3080*	2290				2200*	2000	6478
3.0m (9.10ft)			5340*	5340*	3870*	3450	3300	2220				2180	1720	6982
1.5m (4.11ft)			7530*	5740	4780*	3190	3180	2110				2290*	1620	7137
0m			6830*	5440	4720	3010	3090	2020				2500	1640	6969
- 1.5m (- 4.11ft)	5090*	5090*	8350*	5400	4640	2950	3060	1990				2770	1820	6450
- 3.0m (- 9.10ft)	9250*	9250*	7340*	5510	4690	2990						3530	2310	5480
- 4.5m (- 14.9ft)														

LIFT CAPACITIES – Dipper Length: 3.00m, 4.70m Monoboom, Trackshoes: 700mm, No bucket.

**JZI40 MONO**

Reach	1.5m (4ft 11in)		3m (9ft 10in)		4.5m (14ft 9in)		6m (19ft 8in)		7.5m (24ft 7in)		Capacity at Max Reach			
													mm	
Load Point Ht.	kg	kg	kg	kg	kg	kg	kg	kg	kg	kg	kg	kg		
7.5m (24.7ft)					2850*	2850*						2580*	2580*	4615
6.0m (19.8ft)					2400*	2400*	2500*	2330				2170*	2170*	6109
4.5m (14.9ft)					2690*	2690*	2730*	2320				2040*	1770	6978
3.0m (9.10ft)			4420*	4420*	3440*	3440*	3040*	2230				2030*	1540	7447
1.5m (4.11ft)			6900*	5880	4410*	3220	3180	2110	2260	1480		2120*	1450	7593
0m			7520*	5420	4710	3000	3070	2000				2240	1460	7435
- 1.5m (- 4.11ft)	4570*	4570*	8430*	5300	4590	2890	3010	1940				2450	1590	6951
- 3.0m (- 9.10ft)	7860*	7860*	7750*	5360	4590	2900	3040	1970				3000	1940	6064
- 4.5m (- 14.9ft)			5890*	5590	3670*	3060						3610	3030	4535

Lift capacity front and rear.

Lift capacity full circle.

- Notes:**
1. The above loads are in compliance with SAE and ISO Hydraulic Excavator Lift Capacity Standards.
  2. They do not exceed 87% of hydraulic lifting capacity or 75% of tipping load.
  3. Rated loads marked with an asterisk (\*) are limited by hydraulic capacity rather than tipping load.

LIFT CAPACITIES – Dipper Length: 2.10m, 4.70m Monoboom, Trackshoes: 700mm, No bucket.

**JZ140 MONO + DOZER**

Reach	1.5m (4ft 11in)		3m (9ft 10in)		4.5m (14ft 9in)		6m (19ft 8in)		7.5m (24ft 7in)		Capacity at Max Reach			
													mm	
Load Point Ht.	kg	kg	kg	kg	kg	kg	kg	kg	kg	kg	kg	kg	mm	
7.5m (24.7ft)			3920*	3920*								3940*	3940*	3046
6.0m (19.8ft)					3290*	3290*						2950*	2950*	5042
4.5m (14.9ft)			3900*	3900*	3460*	3460*	3170*	2370				2700*	2320	6068
3.0m (9.10ft)			6070*	6070*	4180*	3570	3540*	2320				2660*	1990	6604
1.5m (4.11ft)					5020*	3340	3480	2230				2800*	1860	6768
0m			6100*	5750	5180	3190	3400	2160				2990	1900	6590
- 1.5m (- 4.11ft)	5450*	5450*	8120*	5770	5130	3150	3400	2150				3370	2140	6038
- 3.0m (- 9.10ft)			6850*	5900	4650*	3220						3960*	2830	4986
- 4.5m (- 14.9ft)														

LIFT CAPACITIES – Dipper Length: 2.50m, 4.70m Monoboom, Trackshoes: 700mm, No bucket.

**JZ140 MONO + DOZER**

Reach	1.5m (4ft 11in)		3m (9ft 10in)		4.5m (14ft 9in)		6m (19ft 8in)		7.5m (24ft 7in)		Capacity at Max Reach			
													mm	
Load Point Ht.	kg	kg	kg	kg	kg	kg	kg	kg	kg	kg	kg	kg	mm	
7.5m (24.7ft)												2970*	2970*	3809
6.0m (19.8ft)					2880*	2880*						2380*	2380*	5530
4.5m (14.9ft)					3130*	3130*	3080*	2410				2200*	2110	6478
3.0m (9.10ft)			5340*	5340*	3870*	3620	3330*	2340				2180*	1830	6982
1.5m (4.11ft)			7530*	6050	4780*	3370	3490	2230				2290*	1720	7137
0m			6830*	5750	5180	3190	3400	2150				2530*	1740	6969
- 1.5m (- 4.11ft)	5090*	5090*	8350*	5720	5110	3120	3360	2110				3040*	1930	6450
- 3.0m (- 9.10ft)	9250*	9250*	7340*	5820	4980*	3160						3780*	2440	5480
- 4.5m (- 14.9ft)														

LIFT CAPACITIES – Dipper Length: 3.00m, 4.70m Monoboom, Trackshoes: 700mm, No bucket.

**JZ140 MONO + DOZER**

Reach	1.5m (4ft 11in)		3m (9ft 10in)		4.5m (14ft 9in)		6m (19ft 8in)		7.5m (24ft 7in)		Capacity at Max Reach			
													mm	
Load Point Ht.	kg	kg	kg	kg	kg	kg	kg	kg	kg	kg	kg	kg	mm	
7.5m (24.7ft)					2850*	2850*						2580*	2580*	4615
6.0m (19.8ft)					2400*	2400*	2500*	2450				2170*	2170*	6109
4.5m (14.9ft)					2690*	2690*	2730*	2450				2040*	1870	6978
3.0m (9.10ft)			4420*	4420*	3440*	3440*	3040*	2350				2030*	1640	7447
1.5m (4.11ft)			6900*	6190	4410*	3400	3480*	2230	2480	1580		2120*	1540	7593
0m			7520*	5730	5170	3170	3370	2120				2340*	1560	7435
- 1.5m (- 4.11ft)	4570*	4570*	8430*	5610	5050	3070	3310	2060				2700	1690	6951
- 3.0m (- 9.10ft)	7860*	7860*	7750*	5670	5060	3070	3340	2090				3300	2260	6064
- 4.5m (- 14.9ft)			5890*	5890*	3670*	3230						3610*	3200	4535

Lift capacity front and rear.

Lift capacity full circle.

- Notes:**
1. The above loads are in compliance with SAE and ISO Hydraulic Excavator Lift Capacity Standards.
  2. They do not exceed 87% of hydraulic lifting capacity or 75% of tipping load.
  3. Rated loads marked with an asterisk (\*) are limited by hydraulic capacity rather than tipping load.

LIFT CAPACITIES – Dipper Length: 2.10m, 5.00m T.A.B., Trackshoes: 700mm, No bucket.

JZ140 T.A.B.

Reach	1.5m (4ft 11in)		3m (9ft 10in)		4.5m (14ft 9in)		6m (19ft 8in)		7.5m (24ft 7in)		Capacity at Max Reach		
													mm
Load Point Ht.	kg	kg	kg	kg	kg	kg	kg	kg	kg	kg	kg	kg	mm
7.5m (24.7ft)												3660*	3857
6.0m (19.8ft)					3070*	3070*						3060*	5563
4.5m (14.9ft)			4130*	4130*	3350*	3350*	3050*	2160				2760*	6506
3.0m (9.10ft)					4030*	3210	3170	2060				2440	7008
1.5m (4.11ft)					4640	2900	3030	1930				2310	7163
0m					4450	2720	2930	1840				2370	6995
- 1.5m (- 4.11ft)			7370*	5030	4420	2690	2920	1830				2650	6478
- 3.0m (- 9.10ft)					4410*	2800						3480*	5343
- 4.5m (- 14.9ft)													

LIFT CAPACITIES – Dipper Length: 2.50m, 5.00m T.A.B., Trackshoes: 700mm, No bucket.

JZ140 T.A.B.

Reach	1.5m (4ft 11in)		3m (9ft 10in)		4.5m (14ft 9in)		6m (19ft 8in)		7.5m (24ft 7in)		Capacity at Max Reach		
													mm
Load Point Ht.	kg	kg	kg	kg	kg	kg	kg	kg	kg	kg	kg	kg	mm
7.5m (24.7ft)					3190*	3190*						3030*	4541
6.0m (19.8ft)					2760*	2760*	2790*	2200				2450*	6053
4.5m (14.9ft)					3070*	3070*	2830*	2210				2240*	6929
3.0m (9.10ft)					3760*	3280	3100*	2090				2180*	7401
1.5m (4.11ft)					4550*	2940	3040	1940	2160	1360		2130	7548
0m					4460	2730	2930	1830				2170	7389
- 1.5m (- 4.11ft)			7190*	4940	4390	2660	2880	1790				2440	6902
- 3.0m (- 9.10ft)			6710*	5110	4460	2730	2990	1890				2990	6007
- 4.5m (- 14.9ft)													

LIFT CAPACITIES – Dipper Length: 3.00m, 5.00m T.A.B., Trackshoes: 700mm, No bucket.

JZ140 T.A.B.

Reach	1.5m (4ft 11in)		3m (9ft 10in)		4.5m (14ft 9in)		6m (19ft 8in)		7.5m (24ft 7in)		Capacity at Max Reach		
													mm
Load Point Ht.	kg	kg	kg	kg	kg	kg	kg	kg	kg	kg	kg	kg	mm
7.5m (24.7ft)					2560*	2560*						2640*	5298
6.0m (19.8ft)					2370*	2370*	2480*	2300				2230*	6637
4.5m (14.9ft)					2700*	2700*	2550*	2250				2070*	7443
3.0m (9.10ft)					3400*	3370	2860*	2120	2220	1420		2020	7885
1.5m (4.11ft)					4230*	2990	3050	1950	2150	1350		1920	8023
0m					4450	2710	2900	1810	2090	1300		1950	7873
- 1.5m (- 4.11ft)			6700*	4800	4330	2600	2830	1740				2120	7419
- 3.0m (- 9.10ft)			7100*	4920	4350	2630	2860	1770				2550	6596
- 4.5m (- 14.9ft)													

Lift capacity front and rear.

Lift capacity full circle.

- Notes:**
1. The above loads are in compliance with SAE and ISO Hydraulic Excavator Lift Capacity Standards.
  2. They do not exceed 87% of hydraulic lifting capacity or 75% of tipping load.
  3. Rated loads marked with an asterisk (\*) are limited by hydraulic capacity rather than tipping load.

LIFT CAPACITIES – Dipper Length: 2.10m, 5.00m T.A.B., Trackshoes: 700mm, No bucket.

JZ140 T.A.B. + DOZER

Reach	1.5m (4ft 11in)		3m (9ft 10in)		4.5m (14ft 9in)		6m (19ft 8in)		7.5m (24ft 7in)		Capacity at Max Reach		
													mm
Load Point Ht.	kg	kg	kg	kg	kg	kg	kg	kg	kg	kg	kg	kg	mm
7.5m (24.7ft)												3660*	3857
6.0m (19.8ft)					3070*	3070*						3060*	5563
4.5m (14.9ft)			4130*	4130*	3350*	3350*	3050*	2280				2760*	6506
3.0m (9.10ft)					4030*	3380	3270*	2180				2660	7008
1.5m (4.11ft)					4750*	3070	3330	2050				2560	7163
0m					4910	2900	3240	1960				2620	6995
- 1.5m (- 4.11ft)			7370*	5340	4880	2870	3230	1950				2930	6478
- 3.0m (- 9.10ft)					4410*	2980						3480*	5343
- 4.5m (- 14.9ft)													

LIFT CAPACITIES – Dipper Length: 2.50m, 5.00m T.A.B., Trackshoes: 700mm, No bucket.

JZ140 T.A.B. + DOZER

Reach	1.5m (4ft 11in)		3m (9ft 10in)		4.5m (14ft 9in)		6m (19ft 8in)		7.5m (24ft 7in)		Capacity at Max Reach		
													mm
Load Point Ht.	kg	kg	kg	kg	kg	kg	kg	kg	kg	kg	kg	kg	mm
7.5m (24.7ft)					3190*	3190*						3030*	4541
6.0m (19.8ft)					2760*	2760*	2790*	2320				2450*	6053
4.5m (14.9ft)					3070*	3070*	2830*	2330				2240*	6929
3.0m (9.10ft)					3760*	3460	3100*	2210				2180*	7401
1.5m (4.11ft)					4550*	3120	3350	2060	2390	1450		2230*	7548
0m					4920	2900	3230	1950				2380*	7389
- 1.5m (- 4.11ft)			7190*	5250	4850	2840	3190	1920				2660	6902
- 3.0m (- 9.10ft)			6710*	5420	4650*	2910	3090*	2010				3080*	6007
- 4.5m (- 14.9ft)													

LIFT CAPACITIES – Dipper Length: 3.00m, 5.00m T.A.B., Trackshoes: 700mm, No bucket.

JZ140 T.A.B. + DOZER

Reach	1.5m (4ft 11in)		3m (9ft 10in)		4.5m (14ft 9in)		6m (19ft 8in)		7.5m (24ft 7in)		Capacity at Max Reach		
													mm
Load Point Ht.	kg	kg	kg	kg	kg	kg	kg	kg	kg	kg	kg	kg	mm
7.5m (24.7ft)					2560*	2560*						2640*	5298
6.0m (19.8ft)					2370*	2370*	2480*	2420				2230*	6637
4.5m (14.9ft)					2700*	2700*	2550*	2380				2070*	7443
3.0m (9.10ft)					3400*	3400*	2860*	2240	2450	1510		2020*	7885
1.5m (4.11ft)					4230*	3160	3250*	2070	2380	1450		2070*	8023
0m					4860*	2890	3210	1930	2320	1390		2160	7873
- 1.5m (- 4.11ft)			6700*	5110	4790	2780	3140	1860				2350	7419
- 3.0m (- 9.10ft)			7100*	5230	4810*	2800	3170	1890				2820	6596
- 4.5m (- 14.9ft)													

Lift capacity front and rear.

Lift capacity full circle.

- Notes:**
1. The above loads are in compliance with SAE and ISO Hydraulic Excavator Lift Capacity Standards.
  2. They do not exceed 87% of hydraulic lifting capacity or 75% of tipping load.
  3. Rated loads marked with an asterisk (\*) are limited by hydraulic capacity rather than tipping load.

## A GLOBAL COMMITMENT TO QUALITY

JCB's total commitment to its products and customers has helped it grow from a one-man business into Britain's largest privately owned manufacturer of backhoe loaders, crawler excavators, wheeled excavators, telescopic handlers, wheeled loaders, dump trucks, rough terrain fork lifts, industrial fork lifts, mini/midi excavators, skid steer loaders, tractors and compaction equipment.

By making constant and massive investments in the latest production technology, the JCB factories have become some of the most advanced in the world.

By leading the field in innovative research and design, extensive testing and stringent quality control, JCB machines have become renowned all over the world for performance, value and reliability.

And with a global sales and service network of more than 650 dealers and agents, we aim to deliver the best customer support in the industry.

Through setting the standards by which others are judged, JCB has become one of the world's most impressive success stories.

