

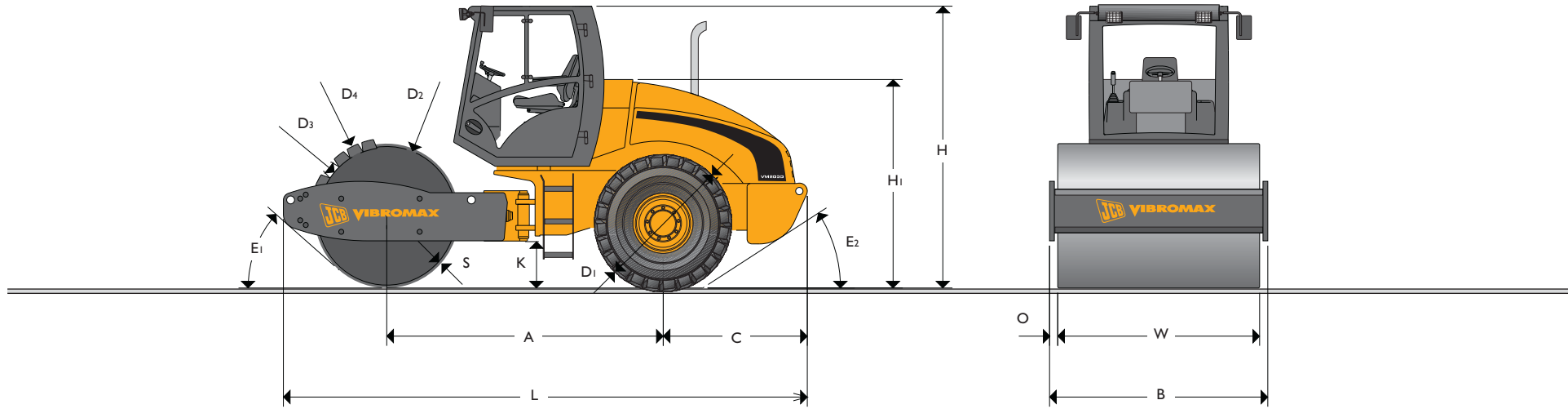

JCB VIBROMAX – COMPACTION EQUIPMENT SELF-PROPELLED VIBRATORY ROLLER VM200D/VM200PD TIER 3



DRUM WIDTH: 2100mm (82.7in)
OPERATING WEIGHT: 19700kg (43431lb) / 19700kg (43431lb)



STATIC DIMENSIONS

Dimensions in millimetres (in)		
A	Wheelbase	3076 (121.1)
B	Overall width	2270 (89.4)
C	Axle to rear face	1660 (65.4)
D1	Wheel diameter	1520 (59.8)
D2	Drum diameter (smooth drum)	1600 (63.0)
D3	Inner diameter padfoot drum	1400 (55.1)
D4	Outer diameter padfoot drum	1600 (63.0)
H	Total travel clearance	2985 (117.5)
H1	Height to top of seat	2245 (88.4)
K	Ground clearance	497 (19.6)
L	Total travel length	5996 (236.1)
O	Overhang	85 (3.3)
S	Drum thickness	40 (1.6)
W	Drum width	2100 (82.7)
E1	Front departure angle	35°
E2	Rear departure angle	29°

OPERATING DATA

		VM200D		VM200PD	
		1	2	1	2
Operating weight	kg (lb)	19700 (43431)		19700 (43431)	
Operating axle load front / rear	kg (lb)	11800 (26015) / 7900 (17416)		11800 (26015) / 7900 (17416)	
Operating linear load front	kg/cm (lb/in)	56.2 (315)			
Vibration stage		1	2	1	2
Exciter frequency	Hz (vpm)	29 (1740)	35 (2100)	29 (1740)	35 (2100)
Nominal amplitude	mm (in)	12 (0.079)	0.75 (0.030)	2 (0.079)	0.75 (0.030)
Centrifugal force	kN (lbf)	370 (83179)	205 (46086)	370 (83179)	205 (46086)
Centrifugal force / drum width	N/cm (lbf/in)	1762 (1006)	976 (557)	1762 (1006)	976 (557)
Compaction depth up to	cm (in)	145 (57)	100 (39)	155 (61)	110 (43)
Working speed (forward/reverse) max.	km/h (mph)	7.6 (4.7)		7.6 (4.7)	
Travel speed (forward/reverse) max.	km/h (mph)	11.8 (7.3)		11.8 (7.3)	
Steering lock angle	degrees	±35		±35	
Vertical oscillation	degrees	±15		±15	
Inner turning radius	m (in)	3.6 (142)		3.6 (142)	
Tyres		23.1 - 26 / 8 PR AWT		23.1 - 26 / 8 PR Dyna Torque II	
Number of padfeet				132	
Height of padfoot	mm (in)			100 (3.9)	
Gradeability up to	degrees (%)	24 (45)		24 (45)	



JCB VIBROMAX – COMPACTION EQUIPMENT SELF-PROPELLED VIBRATORY ROLLER VM200D/VM200PD TIER 3



ENGINE

Six-cylinder, water-cooled, four-stroke, turbo-charged diesel engine with charge air cooler.

Make		Cummins
Model		QSB6.7
Piston displacement	cm ³	6699
Performance – DIN 6271	kW (hp)	129 (173)
Operating speed	min ⁻¹ (rpm)	2200
Starting device		Electric motor
Air cleaner		Dry cartridge + safety cartridge
Fuel filter		Cartridge

PROPULSION

Infinitely variable hydrostatic direct drive by variable displacement motor on rear axle and drum, Multidisc self-locking differential (NoSPIN).

EXCITER DRIVE

Electrically controlled hydrostatic direct drive on drum.

EXCITER

Single-shaft circular exciter with overturning weights.

STEERING SYSTEM

Servo assisted center articulation with vertical oscillation.

SERVICE CAPACITIES

Fuel	litres (US gal)	320 (84.5)
Engine oil (engine)	litres (US gal)	14.5 (3.8)
Gear oil (exciter)	litres (US gal)	12 (3.2)
Hydraulic oil	litres (US gal)	80 (21.1)
Coolant	litres (US gal)	19 (5.0)

BRAKING SYSTEM

Service brake: Hydrostatic propulsion system.
Parking brake: Hydraulically released multi-disk brake on rear axle and drum drive.
Emergency brake: Electrically controlled, disk brake on rear axle and drum drive.

ELECTRICAL SYSTEM

Voltage	V	12
Battery capacity	Ah	143
Alternator	A	max. 95

INDICATORS AND SWITCHES

Hour meter, fuel, engine temperature, engine oil pressure, battery charging current, hydraulic oil and air filter condition, parking brake, neutral position control lever, speed range selection, frequency, AVC (automatic vibration control, acoustic back-up alarm). Optional lighting, turn signal, hazard-warning lights.



JCB Vibromax Compaction Equipment GmbH, PO Box 230149, 40087 Düsseldorf, Germany, Erkrather Straße 343, 40231 Düsseldorf, Germany. Tel: +49 (0) 2 11 - 9 86 63. Fax: +49 (0) 2 11 - 9 86 65 55. Web: <http://www.jcbvibromax.de>

JCB Vibromax America Inc, 2823 Carlisle-Avenue, Racine, WI, 53404, USA. Tel: +1 262-637-8111. Fax: +1 262-637-8211.

JCB Vibromax Singapore, Representative Office, 72 Pasir Ris Heights, Singapore 519279. Tel: +65 6583 8297. Tel: +65 6583 8301.

JCB reserves the right to change specifications without notice. Illustrations shown may include optional equipment and accessories. The JCB logo is a registered trademark of J C Bamford Excavators Ltd.



9999/5160 9/08 Issue 4

A Product
of Hard Work