



# 275 VX

FROM THE INNOVATOR OF VACUUM EXCAVATION



[CEA.NET.AU](http://CEA.NET.AU)



# 275 VX



FEATURES	275 VX
Mountings	Skid Trailer
Spoils Capacity (gal/L)	250 gal / 946 L
Water Capacity (gal/L)	100 gal / 378 L
Engine	31HP Deutz Diesel
Fuel capacity	68 L
Dual LED Work Lights & Strobe	Standard
Warranty	1 Year or 1,000 Hours
OPERATOR CONTROLS	
Controls Location	Front Curbside w/ Lockable Cabinet
Hour Meter/Tachometer/ Vacuum Gauge	Standard
Water Supply Reel	Curb Side Rear
Load Level Indicator & Auto Shutoff	Sight Glass / Mechanical Shutoff
Reverse Flow	Standard
SPOILS TANK DETAILS	
Hydraulic Hoist Unload	Single Cylinder
Full Opening Rear Door	Hydraulically Operated
Rear Door Latch	Manual Spider Lock
Inlet Valve Size/Drain Valve Size	4" / 4" - 10.16 cm / 10.16 cm
SKID DETAILS	
Skid Mount - Height x Length x Width (m)	1.83 m x 2.79 m x 2.16 m
Skid Mount Empty Weight	1,586 kg
VACUUM PUMP / BLOWER DETAILS	
Vacuum Pump / Blower Type	Positive Displacement Lobe Pump
CFM / Max Hg	600 CFM / 15" Hg
Reverse Flow	Standard
Cyclo Separator Air Filter Type Capacity	Cyclo-Separator with 3 Micron Filter, 16,750 Sq In Filter Media
WATER SYSTEM DETAILS	
Water Pressure / Water Supply	3,000 PSI / 18.9l/min
Electronic Low Water Shut-Off	Standard
Auto water Pump Unloader to Re- duce Engine Loading & Wear	Standard
Water Pump Drive	Belt w/ Electric Clutch
Water Supply Hose	50' x 3/8" ID - 15.24m x .95cm
Water Supply Reel Location	Curb Side Rear

\*SPECS ON MACHINE MAY CHANGE



# KEY FEATURES

## CONTROLS & REMOTE



THE CONTROLS LOCATED ON THE FRONT CURBSIDE PROVIDES EASY ACCESS WITH A LOCKABLE CABINET AND MAGNETIC REMOTE THAT CAN EXTEND IF OPERATING FROM A DISTANCE IS NEEDED.

## WATER TANK

THE WATER TANK IS CAPABLE OF HOLDING 100 GALLONS (378 LITRES). THE TANKS ALSO INCLUDE A LOW WATER SHUTOFF FEATURE. A SINGLE TANK PROVIDES HIGHER RELIABILITY AND LESS MAINTENANCE REQUIREMENTS

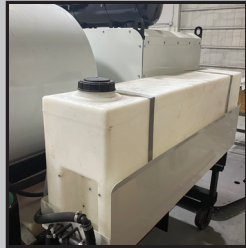

## REVERSE FLOW



THE 275 VX OFFERS REVERSE FLOW STANDARD, WHICH ALLOWS YOU TO PRESSURIZE THE TANK FOR EASY OFFLOADING AND ASSISTS IN CLEARING HOSE OBSTRUCTIONS.

## SPIDER DOOR LOCK

THE SPOIL TANK DOOR IS MECHANICALLY LOCKED WITH THE SPIDER DOOR LOCKING SYSTEM AND HYDRAULICALLY OPENED. THE DOOR OPENS 75 DEGREES WHICH PROVIDES THE INDUSTRY'S WIDEST OPENING REAR DOOR IN IT'S CLASS.



## BAGHOUSE FILTRATION



THE BAGHOUSE FILTRATION THAT FOLLOWS THE CYCLO-SEPARATOR FILTRATION HAS A WASHABLE AND REUSABLE FILTER THAT IS ACCESSED EASILY TO BE BLOWN OUT AND CLEANED AFTER USE.



THE RING-O-MATIC 275 VX OFFERS THE SAME POWER AS OUR LARGER UNITS WITHIN A COMPACT DESIGN. THE 275 VX IS A PERFECT MACHINE FOR MANY APPLICATIONS FROM PUTTING IN FENCE POSTS TO MID TO LARGE SCALE LANDSCAPING JOBS. THIS MACHINE SHOWCASES THE WIDE VARIETY OF OUR EQUIPMENT LINE UP AND CAN BE USED FOR TRADITIONAL POT HOLING AND SLOT TRENCHING AS WELL.

## APPLICATIONS:

ANIMAL WASTE CLEANUP  
 CAR WASH PIT CLEANING  
 CATCH BASIN CLEANING  
 CEMETERY HEADSTONE RESETTING  
 CITY UTILITY MAINTENANCE  
 MUNICIPALITY USE  
 CONCRETE SLURRY MANAGEMENT  
 DAIRY FARM CLEAN UP  
 DAYLIGHTING  
 FENCE POST SETTING  
 FERTILIZER PLANT CLEANUP  
 FOUNDATION STABILISATION  
 GRAIN ELEVATOR CLEANUP  
 HYDRO EXCAVATION  
 LIFT STATION CLEANING  
 LOCATING UNDERGROUND UTILITIES  
 MANHOLE CLEANUP / MAINTENANCE

MICRO-TUNNELING  
 MUD REMOVAL  
 POND CLEANUP  
 POT HOLING  
 PRECISE LANDSCAPING  
 RETENTION POND CLEANING  
 ROAD SIGN SETTING  
 SILO CLEANING  
 SLOT TRENCHING  
 SLURRY REMOVAL  
 STALL CLEANING  
 STORM DRAIN CLEANING  
 TREATMENT PLANT CLEANING  
 UTILITY POLE SETTING  
 WATER VALVE CLEANING  
 WET / DRY REMOVAL



1300 788 757



# 275 VX

## SKID DIMENSIONS

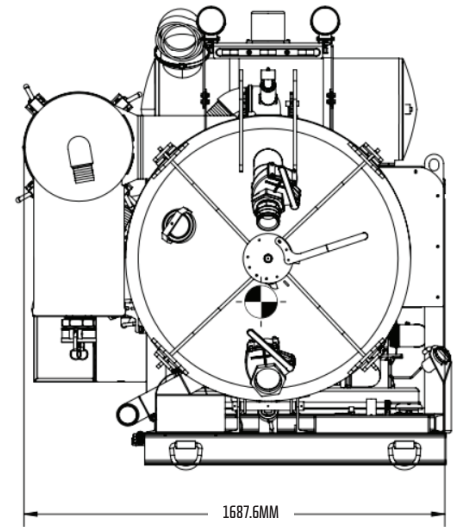
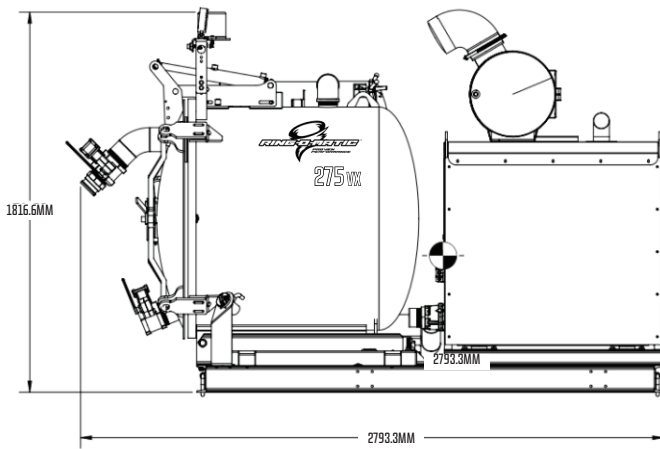

**RING-O-MATIC ALSO OFFERS A FULL RANGE OF TRUCK MOUNTED VACUUM EXCAVATORS. FOR ALL TRUCK MOUNT SPECIFICATIONS PLEASE CONTACT CEA  
1300 788 757  
CEA.NET.AU**



BRISBANE  
SYDNEY  
MELBOURNE

ADELAIDE  
PERTH

All equipment shown is for illustrative purposes only and may display optional accessories or components. Please contact your local Ring-O-Matic dealer or Corporate sales team for more information about machine specifications. Ring-O-Matic reserves the right to make changes in engineering, design and specifications; add improvements; or discontinue manufacturing at any time without notice or obligation. RING-O-MATIC, RING-O-MATIC Corporate logo, Ring-O-Matic Company R logo, PROVEN PERFORMANCE and VIPER are trademarks of Ring-O-Matic, INC. in the U.S. and / or other countries.